



YFB5 系列高效率粉尘防爆型
三相异步电动机 (机座号 71~355)
YFB5 SERIES HIGH EFFICIENCY DUST
EXPLOSION-PROOF
THREE PHASE INDUCTION MOTORS
(Frame 71-355)

使用说明书

Maintenance Instruction

安徽皖南电机股份有限公司
Anhui Wannan Electric Machine Co., Ltd

衷心感谢您选购、使用皖南电机。

在使用电动机之前，请扫码仔细阅读本说明书，以便您正确的使用和维护。

1 产品概述

YFB5 系列高效率粉尘防爆型三相异步电动机，外壳防护等级为 IP65（尘密型）。冷却方式为 IC411（全封闭自扇冷式）。

本系列电动机符合 GB/T 3836.1-2021《爆炸性环境 第 1 部分：设备 通用要求》、GB/T 3836.31-2021《爆炸性环境 第 31 部分：由防粉尘点燃外壳“t”保护的的设备》和 Q/WN.307-2023《YFB5 系列高效率粉尘防爆型三相异步电动机技术条件（机座号 71-355）》的规定制成尘密型，适用于工厂爆炸性粉尘场所，作一般传动用。其防爆标志为 Ex tb IIIC T130℃ Db。该系列效率符合 GB18613-2020（1 级能效）。

1.1 型号说明

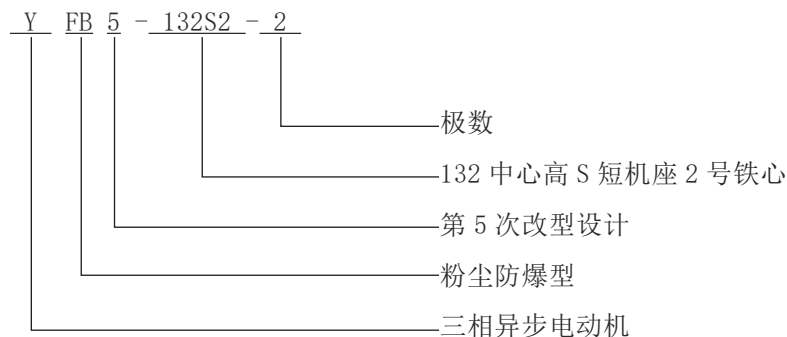

1.2 防爆标志说明（举例）

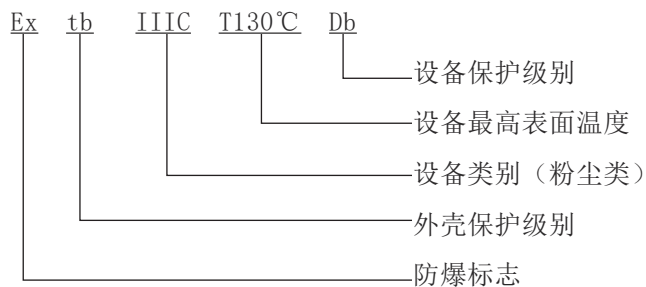

2 电动机的主要规格及安装结构型式

2.1 电动机的机座号与转速及功率的对应关系见表 1。

表 1

机座号	同 步 转 速 r/min				
	3000	1500	1000	750	600
	功 率 kW				
71M1	0.37	0.25	0.18	-	
71M2	0.55	0.37	0.25		

表 1 (续)

机座号	同步转速 r/min					
	3000	1500	1000	750	600	
	功率 kW					
80M1	0.75	0.55	0.37	0.18	—	
80M2	1.1	0.75	0.55	0.25		
90S	1.5	1.1	0.75	0.37		
90L	2.2	1.5	1.1	0.55		
100L1	3	2.2	1.5	0.75		
100L2		3		1.1		
112M	4	4	2.2	1.5		
132S1	5.5	5.5	3	2.2		
132S2	7.5					
132M1	—	7.5	4	3		
			5.5			
160M1	11	11	7.5	4		—
160M2	15			5.5		
160L	18.5	15	11	7.5		
180M	22	18.5	—	—		
180L	—	22	15	11		
200L1	30	30	18.5	15		
200L2	37		22			
225S	—	37	—	18.5		
225M	45	45	30	22		
250M	55	55	37	30		
280S	75	75	45	37		
280M	90	90	55	45		
315S	110	110	75	55	45	
315M	132	132	90	75	55	
315L1	160	160	110	90	75	
315L2	200	200	132	110	90	
355S1	185	185	160	132	90	
355S2	200	200				
355M1	220	220	185	160	110	
355M2	250	250	200		132	
355L1	280	280	220	185	160	
355L2	315	315	250	200	185	
355L3	355	355	280	220	200	
355L4	375	375	315	250	220	

注：S、M、L 后面的数字 1、2 分别代表同一机座号和转速下不同的功率。

2.2 电动机的结构及安装型式见表 2。

表 2

机座号	结构及安装代号 (IM)
80 ~ 112	B14、B34、V18
80 ~ 160	B3、B5、B6、B7、B8、B35、V1、V3、V5、V6、V15、V17、V35、V37
180 ~ 280	B3、B5、B35、V1
315 ~ 355	B3、B35、V1

注：对其他安装方式供货的电动机，应符合订货的技术协议或合同的规定。

3 电动机主要结构

3.1 电动机的接线盒位于电动机顶部，制成六个接线端子。内设一个接地端子，并按其需要分别制成一个或二个出线口。在接线盒座与接线盒盖的止口处加设密封圈。

3.2 电动机转轴旋转部位采用轴面油封和 6 级防尘装置保护。

3.3 电动机机座号 H71 ~ 132 的轴承采用密封轴承，机座号 H160 及以上电动机设置了不停机注、排油装置。

3.4 电动机主体结构见图 1、接线盒结构见图 2。

4 运行使用条件

4.1 电动机防护等级 IP65。

4.2 电动机额定电压为 220V、230V、240V、380V、400V、415V、460V、480V、660V、690V、720V、760V、796V、220/380V、230/400V、240/415V、380/660V、400/690V、415/720V、440/760V、460/796V，额定频率为 50Hz，绝缘等级为 F 级。

4.3 电动机的定额是以连续工作制 (S1) 为基准的连续定额，允许满压起动。

4.4 电动机 3KW 及以下为 Y 接法，3KW 及以上时为 Δ 接法。

4.5 电动机所容许的场所

电动机适用于工厂中具有点燃温度高于 130℃ 的粉尘层或粉尘云，与空气混合能达到爆炸浓度的 21 区或 22 区场所，在满足上述条件下，无论是户内或户外（半露天），均可使用本系列电动机。

4.6 在下列海拔和环境空气下，电动机能额定运行。

- a. 环境空气温度随季节而变化，但一般不超过 $-20 \sim +40^{\circ}\text{C}$ ；
- b. 海拔不超过 1000m。

注：对环境空气温度和海拔与 a、b 不同时，依电机铭牌或订货合同为准。

5 防爆要点

5.1 本系列电动机为粉尘防爆型。电动机各结合面间有 O 型密封圈和密封垫、转轴贯通处有 6 级防尘密封装置应能有效地阻止外部环境里的粉尘进入电机内部引起粉尘爆炸并且电机外壳温度不足以引燃粉尘。

5.2 防爆型电动机的元件（如机座、端盖、防尘装置、接线盒盖、接线盒座、密封垫等）。

5.3 联接防爆外壳的螺栓均装有弹簧垫圈，防止自行松脱。

5.4 在额定工作状态下，电动机外壳表面温度应 $\leq 130^{\circ}\text{C}$ ；电缆进线 $\leq 70^{\circ}\text{C}$ ；

5.5 配用的电缆引入装置已取得防爆合格证和 CCC 证书，引入装置夹紧试验时拉力值按照 GB/T3836.1-2021 附录 A.3 的规定降低到 25% 进行试验合格，不具备足够夹紧措施，用户应提供夹紧措施以防电缆受到的拉力或扭矩传递到连接件上；

6 安装



警告！

搬运电动机时，应小心谨慎！

强烈的摔、碰、震会严重损坏轴承及防爆元件。

吊装带有吊攀的电机时，一定要将吊攀旋紧。

6.1 安装前的准备

6.1.1 仔细检查电动机外观是否完好、核对电动机铭牌内容是否与实际需求相符。

6.1.2 电动机是否有防爆标志、防爆合格证编号和生产许可证。

6.1.3 防爆外壳各零部件联接正确，紧固可靠无松动。

6.1.4 所有防爆元件应无裂纹或影响防爆性能的缺陷。

6.1.5 取下接线盒盖检查电动机定子绕组绝缘电阻应不低于 $20\text{ M}\Omega$ 。

6.2 安装

6.2.1 电动机的安装应由专业技术人员完成。

6.2.2 电动机宜采用弹性联轴器传动。

6.2.3 电动机轴中心与被传动的主机轴中心要保持一致。

6.2.4 对带底脚的电动机，安装平面应平整、坚固。

6.2.5 联接电动机的电源线（电缆）不宜过细、过长。

6.2.6 引入的电缆芯线要接在两弓型垫圈之间，注意芯线的飞刺不要突出，引入接线孔时应防止线芯损伤，引入电缆还须用接线压板和弓形垫圈压紧固定，防止窜动。

6.2.7 六端子接线盒通过连接片改变接法，可适应两种不同电压需要（见接线盒盖内侧）。对有两个进线口的接线盒，当引入一根多芯电缆只使用一个进线口时，另一个进线口的堵棒不得拿掉，否则将失去防爆性能。

6.2.8 电动机的相序 U、V、W 须与接入外电源相序 A、B、C 相对应，电动机转向从轴伸端视之为顺时针方向，否则电动机将反转。

6.2.9 电动机内、外接地螺栓必须可靠接地。

6.2.10 电动机接好线，经检查确认无误后，方可接通电源进行空载试运转，并观察电机有无异常现象，待空转正常后方可投入负载运行。

警告!



- 1、电源电压的波动不得超过额定电压的 95% ~ 105%。
- 2、必须接好接地线。
- 3、电机运行若有异常立即停机。
- 4、保持身体、衣物远离电动机运转部分。

7 使用须知

YFB5 系列电动机除了应遵循一般电动机的使用方法外，还必须遵循以下几项要求以保证电动机在使用中安全可靠。

7.1 根据场所的危险程度，需正确选择电动机的防爆类型（防爆标志含义参考 1.2 “防爆标志说明”），电动机所适用的区域场所见表 3。

表 3

危险场所	21 区	22 区
电机类型	Da/Db	Da/Db/Dc

注：21 区

在正常运行过程中，可能出现粉尘数量足以形成可燃性粉尘与空气混合物但未划入 20 区的场所。该区域包括，与充入或排放粉尘点直接相邻的场所、出现粉尘层和正常操作情况下可能产生可燃浓度的可燃性粉尘与空气混合物的场所。

22 区

在异常条件下，可燃性粉尘云偶尔出现并且只是短时间存在、或可燃性粉尘偶尔出现堆积或可能存在粉尘层，并且产生可燃性粉尘空气混合物的场所。如果不能保证排除可燃性粉尘堆积或粉尘层时，则应划分为 21 区。

7.2 电动机的使用场所及环境条件必须符合表 3 条的规定，使用时应及时清理电机表面覆盖的粉尘，避免粉尘堆积，清理过程中应避免扬尘。

7.3 YFB5 系列电动机采用 F 级绝缘，在海拔高度不超过 1000mm，环境空气温度不超过 40℃时，定子绕组温升限值（电阻法）应不超过 80K；轴承的允许温度（温度计法）应不超过 95℃，电动机在起动、额定运行时，其任何部件的最高表面温度不得超过 T130℃的规定。

7.4 电动机的起动方式：YFB5 系列电动机功率在 3kW 及以下者，绕组已接为 Y 形，4kW 以上绕组已接为△形，接线盒内有六个接线端子，可直接与三相电源连接，其电源电压 380V，频率 50Hz 满压起动，也可为用户特殊要求的双电压电动机，接线盒上有接线指示图，对电压、频率有特殊要求的电机，依铭牌标注为准。

7.5 电动机的传动方式：YFB5 系列电动机可借联轴器、正齿轮或三角皮带轮与传动机构相连接，但不允许用平皮带轮与机构相连接。

7.6 电动机的接地：YFB5 系列电动机使用前及使用过程中，各接地螺栓应可靠的接地。

7.7 电动机的紧固：电动机的所有紧固件，特别是接线盒部分，不允许任意拆卸或松动，对于使用前必须拆卸的部分，如接线盒盖，在接线完毕后，必须先将内部擦干净，然后按原来的装配要求可靠地装配好，其中所有密封胶垫在拆装后，均不得有挤出或挤入现象，以确保电动机防护性能不至降低。

电机机座与端盖、轴承外盖接合面处加的氯丁泡沫橡胶密封垫，按 0.2 ~ 0.5 压缩量加在配合面处，

接线盒座与机座间用丁腈橡胶密封垫，安装时保证压紧可靠，如老化、失效必须按原尺寸更换，不准将密封垫去掉不用，否则将失去防爆性能，并影响电机正常运行。

8 维修与检修

YFB5 系列电动机除了应遵循一般电动机的维修与检修规定以外还应注意如下几个方面的问题。

8.1 电动机在使用过程中应做到定期进行检修，一般要求每半年至少检修一次，每年大检修一次。

8.1.1 小检修的主要项目：

- a. 检查所有接地接触面是否洁净光泽。
- b. 检查电气接点是否牢靠清洁，接触是否良好。
- c. 检查接线盒内，轴承密封部位润滑是否清洁、正常。
- d. 检查所有机械连接是否牢靠，如外风扇、风罩、密封垫等。
- e. 检查风扇距风扇罩的距离，须不小于风扇直径的 1%，但最小为 1mm。

8.1.2 大检修的项目包括全部小检修项目外，尚须进行下述工作：

- a. 清洁电动机内部及线圈内部的积尘、污物等。
- b. 正常情况下更换润滑脂（封闭轴承在使用寿命期内不必更换润滑脂），一般使用的润滑脂牌号为锂基润滑脂 ZL-2。
- c. 检查电动机绕组绝缘、端部绑扎、电气接头等。
- d. 更换老化的橡胶密封垫、密封油封等。橡胶密封油封的更换时间见铭牌，密封垫、密封油封等密封件均为易损件，更换时应小心。

8.2 电动机在运行中如发现有不正常的声响或润滑油变质，均应进行检修或更换轴承（轴承规格见表 4）。

8.2.1 轴承每运行 2500 小时（约半年）需至少检查一次，如发现轴承润滑脂变质必须及时更换（封闭式轴承在使用寿命期限内不必更换润滑脂）。更换前，须将轴承内外盖、贮油腔内的废油以及排油装置的油管、油杯内的废油清理干净，并将轴承清洗干净。

8.2.2 润滑脂推荐采用锂基润滑脂 ZL-2，润滑脂使用温度范围：-20~+120℃，轴承预期使用寿命为 50000h。油脂添加量以加到轴承容腔的 1/3 ~ 1/2 左右为宜。轴承润滑油使用量和加油时间见附表 5。

8.3 电动机在检修拆卸后，对于所有的配合面均须擦干净，然后均匀地抹上一层密封胶油再进行装配，对于所有的联接螺栓在装配时也应涂上一层密封胶油。如须重新安装电机的引接线时，将电机引接线固定在电机的接线架上。

8.4 电动机绕组接头、绕组引出线与电缆接头等，均不允许承受机械应力，接头处允许采用下述一方法连接。

- a. 能防止松动的螺母螺钉连接；
- b. 挤压连接；
- c. 导线先用机械方式连接后再用锡焊连接；
- d. 硬焊（如银焊、铜焊、银铜焊等）连接；
- e. 溶焊连接。

8.5 电动机各零部件在检修后的装配过程中，要注意保证风扇与风扇罩的间距不得小于风扇直径的 1%，但最小为 1mm。

表 4 机座号和适用轴承型号对照表

机座号	极 数	轴伸端	非轴伸端
71	2 ~ 6P	6202-2RZ	6202-2RZ
80	2 ~ 8P	6204-2RZ	6204-2RZ
90	2 ~ 8P	6205-2RZ	6205-2RZ
100	2 ~ 8P	6206-2RZ	6206-2RZ
112	2 ~ 8P	6206-2RZ	6206-2RZ
132	2 ~ 8P	6208-2RZ	6208-2RZ
160	2 ~ 8P	6309-2RZ	6309-2RZ
180	2 ~ 8P	6311-2RZ	6311-2RZ
200	2 ~ 8P	6312-2RZ	6312-2RZ
225	2 ~ 8P	6313-2RZ	6312-2RZ
250	2P	6313	6313
	4 ~ 8P	6314	6313
280	2P	6314	6314
	4 ~ 8P	6317	6314
315	2P	6317	6317
	4 ~ 10P	NU319	6319
355	2P	6319	6319
	4 ~ 10P	NU322	6322

注：电机用轴承型号以实物使用型号为准，如有变动，恕不另行通知。

表 5 轴承润滑油使用量和加油时间

机座号	极 数	油脂量 (g)	加油时间 (h)
160、180	2	20	4200
	4	20	7000
	6	20	9000
200	2	25	3100
	4	25	6500
	6	25	8500
225	2	25	3100
	4	30	6200
	6	30	6200
250	2	30	2600
	4	35	6000
	6	35	8000
280	2	35	2000
	4	40	5500
	6	40	7500
315	2	30	2500
	4-10	36	2500
355	2	36	2500
	4	47	2500
	6-12	47	2500



图1 电动机主体结构 (B3)



图2 接线盒结构

We are truly grateful for your purchasing of Wannan Motors. Before using the motor, please scan the QR code to read the manual so as to use and maintain the motor in a right way.

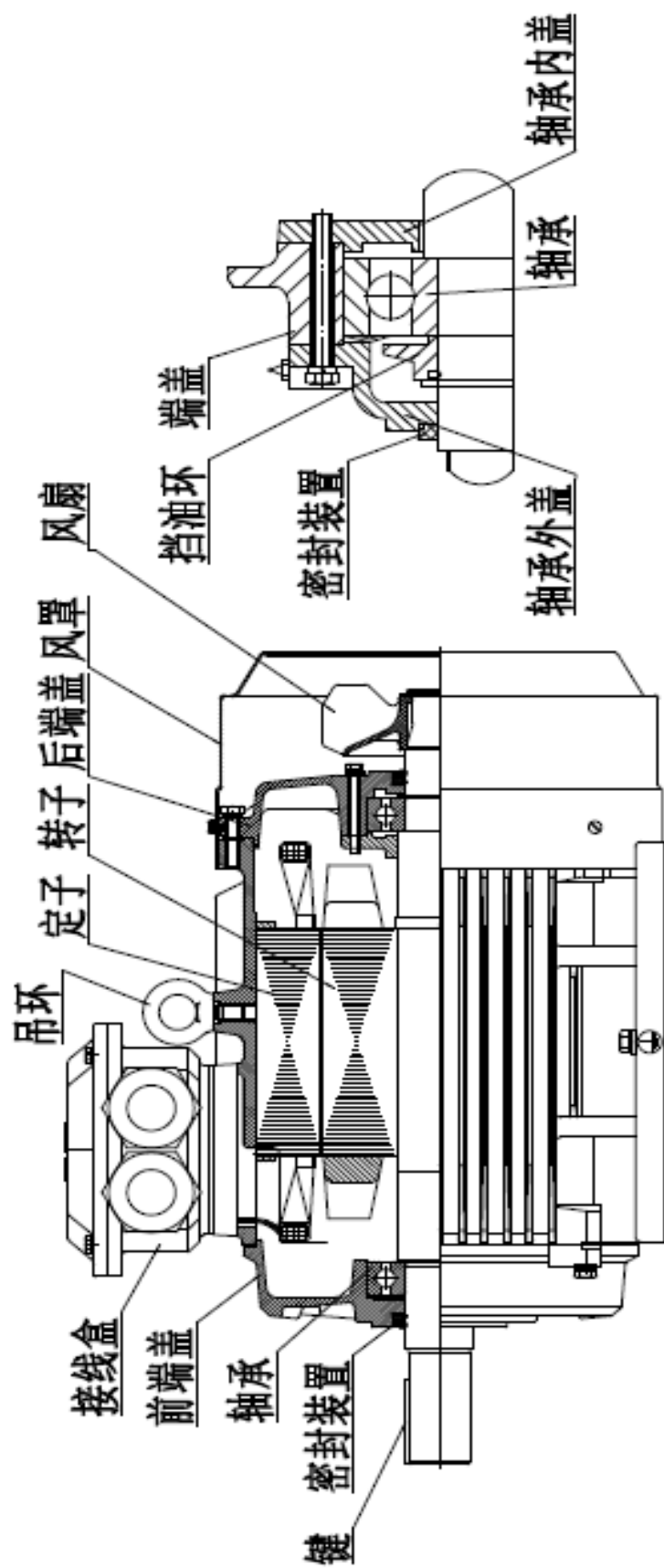
1. Summary

YFB5 series high-efficiency dust explosion-proof three phase induction motor, IP 65 (dust-tight), IC411 cooling method, which conforms to the request of GB 3836.1-2021 “Electrical Apparatus for use in the presence of combustible dust--Part 1 General Request”、GB/T3836.31-2021 “Explosive atmosphere-Part 31: Equipment dust ignition protection by enclosure ‘t’” and Q/WN.307-2023 “Specification of YFB5 series high efficiency dust explosion-proof three phase induction motor (Frame size 71~355)” are manufactured as dust-tight and is suitable for applying in plants with combustible dust for driving. Ex-code is Ex tb IIC T130°C Db. Motor efficiency meets Grade 1 value of standard GB18613.2020

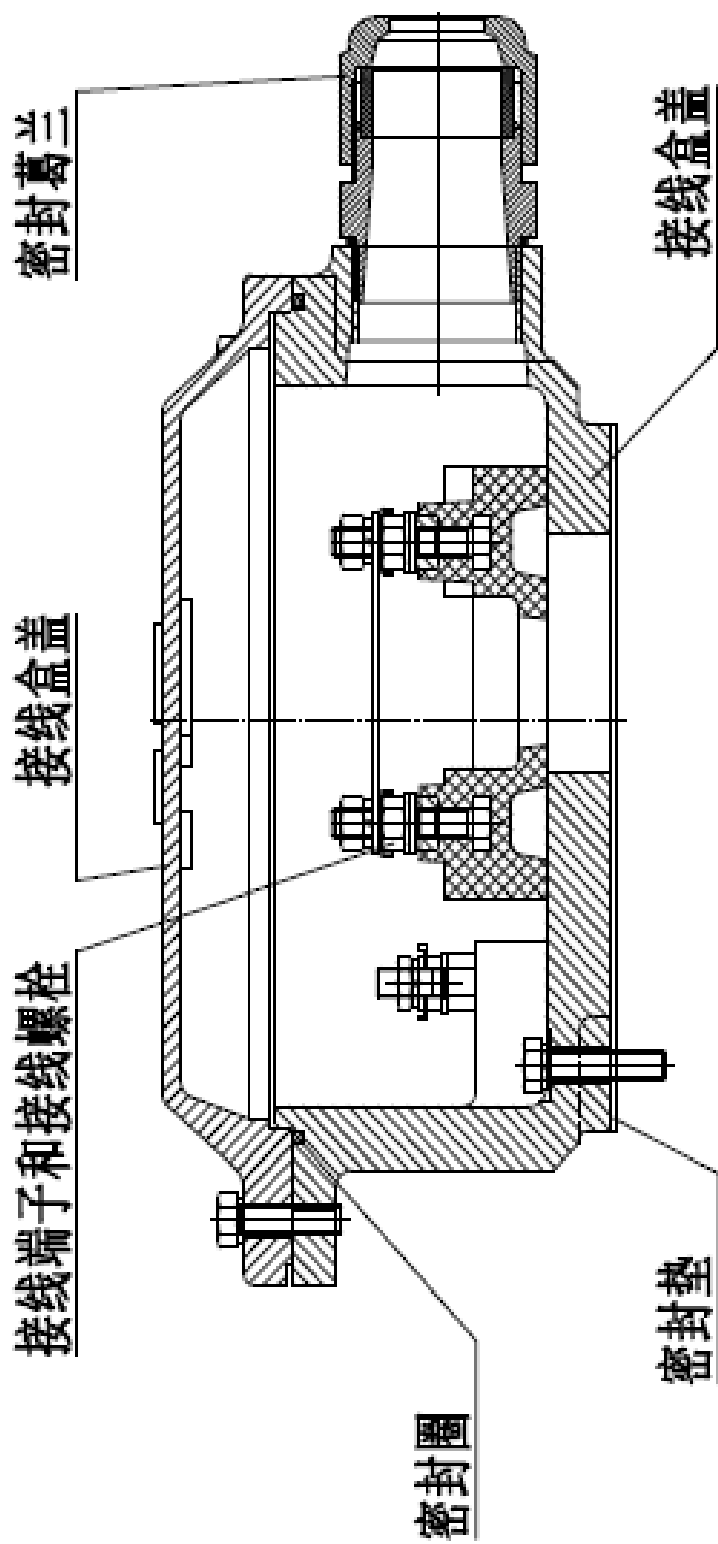
1.1 Type Designation

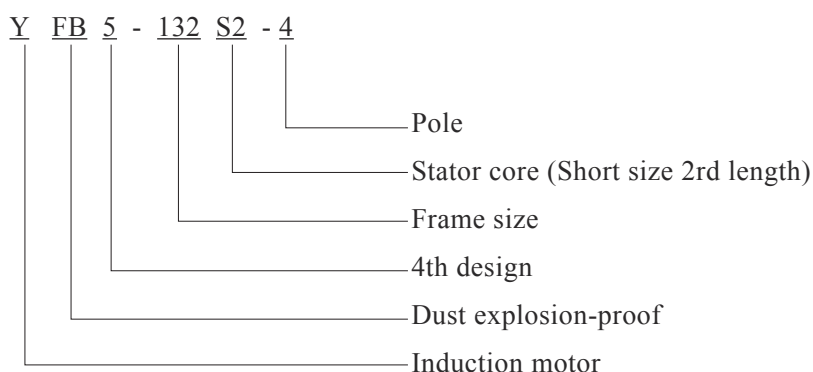

1.2 Ex-code Illustration

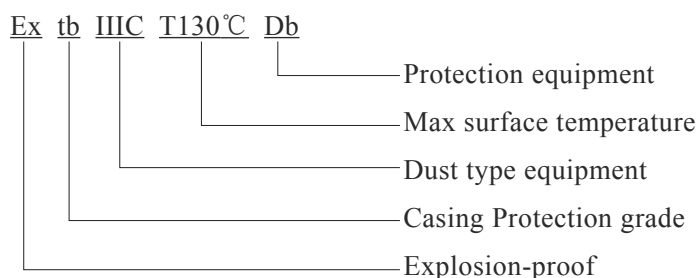

2 Motor specification and mounting type

2.1 Motor frame's relation to power and speed see table 1

Table 1

Frame Size	Synchronous speed r/min				
	3000	1500	1000	750	600
Power kW					
71M1	0.37	0.25	0.18	-	-
71M2	0.55	0.37	0.25	-	
80M1	0.75	0.55	0.37	0.18	

Table 1 (continued)

80M2	1.1	0.75	0.55	0.25	
90S	1.5	1.1	0.75	0.37	
90L	2.2	1.5	1.1	0.55	
100L1	3	2.2	1.5	0.75	
100L2		3		1.1	
112M	4	4	2.2	1.5	
132S1	5.5	5.5	3	2.2	
132S2	7.5				
132M1	-	7.5	4	3	
132M2			5.5		
160M1	11	11	7.5	4	
160M2	15			5.5	
160L	18.5	15	11	7.5	
180M	22	18.5	-	-	
180L	-	22	15	11	
200L1	30	30	18.5	15	
200L2	37		22		
225S	-	37	-	18.5	
225M	45	45	30	22	
250M	55	55	37	30	
280S	75	75	45	37	
280M	90	90	55	45	
315S	110	110	75	55	45
315M	132	132	90	75	55
315L1	160	160	110	90	75
315L2	200	200	132	110	90
355S1	185	185	160	132	90
355S2	200	200			
355M1	220	220	185	160	110
355M2	250	250	200		132
355L1	280	280	220	185	160
355L2	315	315	250	200	185
355L3	355	355	280	220	200
355L4	375	375	315	250	220
Tip: The figures 1、2 behind S、M、L refer to different output power of the motors with the same frame and speed.					

2.2 Motor frame's relation to mounting type see table 2

Table 2

Frame size	Structure and mounting (IM)
71 ~ 112	B14、B34、V18
71 ~ 160	B3、B5、B6、B7、B8、B35、V1、V3、V5、V6、V15、V17、V35、V37
180 ~ 280	B3、B5、B35、V1
315 ~ 355	B3、B35、V1

Tips: The motor of other installation type, the technical agreement or order shall be prevail.

3 Motor's subject structure

3.1 Terminal box, at the top of the motor, with 6 connection terminals and 1 grounding terminal, can be manufactured with 1 or 2 cable outlet. Rabbet between terminal box body and its cover shall be fitted with sealing ring.

3.2 Motor rotation part shall be fitted with shaft surface grease seal and level-6 dust-tight protection device.

3.3 Motor of frame 71~132 adopt seal bearing, motor of frame 160 or above adopt open bearing and on-the-go refueling and discharging device.

3.4 Subject structure of the motor see figure 1, and the structure of terminal box see figure 2.

4 Application circumstance

4.1 Motor IP 65 protection grade

4.2 The rated voltage of the motor is 220V、230V、240V、380V、400V、415V、460V、480V、660V、690V、720V、760V、796V、220/380V、230/400V、240/415V、380V/660V、400V/690V、415/720V、440/760V、460/796V, rated frequency is 50Hz, insulation is in F class

4.3 The rating here refers to the continuous rating power on the basis of S1 duty system, the motor allows full voltage starting.

4.4 Motor of 3kW and below: single voltage like 220V、230V、240V is Δ connection, 380V、400V、415V、460V、480V is Y connection; Motor of 4kW and above: single voltage like 380V、400V、415V、460V、480V is Δ connection, 660V、690V、720V、760V、796V is Y connection. All dual-voltage motors: low voltage connected as Δ type, high voltage connected as Y type.

4.5 Allowable atmosphere

The motor is suitable for the plant where the maximum temperature is 130°C, and the density of dust layer, or mixture of dust cloud and air reach the extend of explosion at Area 21 and Area 22. If the circumstance meets above condition, this series motor can be applied indoors or outdoors (semi open).

4.6 The motor can rating operate in the following height and circumstance.

a. Ambient temperature varies as seasonal variation, but the temperature shall not beyond the range -20°C ~+40°C ;

b. Not exceed 1000m above the sea level

Tip: In case the environment and height differ from a、b, the nameplate and purchase order shall be prevail.

5 Explosion-proof feature

5.1 This series motor highlights its dust explosion-proof feature. With the structure of o-type sealing ring or sealing gasket fitted between each juncture plane and the level-6 dust-tight device, the motor is able to prevent explosion by separating external dust from its internal parts, and ensure that the casing temperature will not reach the ignition point of the dust.

5.2 Components of the explosion-proof motor include frame, end cover, bearing inner cover, connection box cover, connection box body etc.

5.3 Spring washer on fastening bolt can prevent the bolts releasing from explosion-proof casing

5.4. When working in rating power, motor casing maximum surface temperature is 130°C , cable outlet maximum temperature is 70°C ;

5.5 The cable-entry device applied are qualified with Ex-proof certificate and CCC certificate. The introduction device are passed in the clamping test with 25% pull force stipulated in the standard of GB/T3836.1-2021 appendix A.3 item, as a result there is no adequate clamping device, user shall have own clamping tool to ensure that the pull force or torque from cable will not pass to connection parts.

6 Installation



Warn!

Handle the motor with care.

Strong fall, impact, vibration will heavily damage motor bearing and other explosion-proof components.

Fasten onto the lifting hook tightly if the motor is moved by the crane.

6.1 Preparation

6.1.1 Check and ensure the appearance of the motor is in good order. Check and ensure that the motor nameplate is consistent with actual requirement.

6.1.2 Inspect the motor's ex-code, ex-certificate No. and manufacture license.

6.1.3 Ensure that all parts of explosion-proof casing have been connected correctly and tightly.

6.1.4 Check and ensure that all explosion-proof components have neither crack nor defect that affects its explosion-proof performance.

6.1.5 Check and measure the insulation resistance of the stator winding, and ensure that the resistance value is no less than 20MΩ.

6.2 Installation

6.2.1 Installation shall be performed by technician.

6.2.2 Spring coupling ought to be used to drive machine.

6.2.3 Keep the motor shaft's center and driven machine shaft's center at the same level.

6.2.4 For the motor with feet, all the feet shall be fixed to sound and flat plane.

6.2.5 Power wires shall be neither too thin nor too long.

6.2.6 The lead-in cable core should be attached between the 2 arched washers, and thorn on the cable core can't be protruding. Be careful to avoid damaging cable core when pulling it out through the cable entry. The lead-in cable shall be fixed by terminal plate and arched washer.

6.2.7 To fit different supply voltage (usually 2 voltage), suitable connection method should be chosen (refer to terminal box cover). For the connection box which has 6 terminals, changing the connection strap is effective way to change its connection method. In case there were 2 cable entry, if one multi-core cable were introduced into one of those, the blank cover at the other entry can't be removed, otherwise it will cause the failure of motor's explosion-proof function.

6.2.8 Motor will rotate clockwise viewed from driving end if the terminals U,V,W are connected to power line phase A, B, C respectively. Otherwise the motor will rotate anti-clockwise.

6.2.9 Ensure the internal & external grounding bolts have been safely grounded.

6.2.10 Correctly connect all wires, turn on power for no-load trial-operation. Only when the motor runs smoothly in the test-running, can it be put into load operation.

Warn!



1. Voltage fluctuation of the supplied power shall not exceed the range 95% ~ 105% of the rating.
2. Connect grounding wire safely.
3. Stop the motor immediately if any abnormal problem occurs.
4. Keep body and clothes far away from rotating parts of motor.

7 Operation notice

Beside the general request, this series motor must abide by some additional rules to ensure its safety and function.

7.1 Choose correct explosion-proof type with concerning of its application plant's danger extent.

Designation of the Ex-mark see 1.2 above

Table 3

Hazardous Area	Area 21	Area 22
Equipment type	Da/Db	Da/Db/Dc

Note: Area 21

Area 21 is the places that has not been classified into Area 20 but in which dust forms in working condition and its quantity may reach the exploding point when mixing with air but.

Area 21 includes such areas as places next to dust charging or discharging point, and the plants where dust layer forms or the mixture of air-combustible dust discharged may reach explosive concentration level under normal operation.

Area 22

In abnormal conditions, the combustible dust cloud occasionally forms and exists for short time, or combustible dust may occasionally accumulates or the dust layer may exist, as well the combustible dust and air will mix. When above mentioned combustible dust accumulation or layer cannot be totally excluded, such places shall be classified into Area

7.2 The applicable circumstance and condition must be in compliance with the stipulation of Table 3. Clean all dust on motor surface before use and during which the raised dust shall be avoided.

7.3 The series motor is of class F insulation. When the altitude exceeds not 1000m and the ambient temperature is no higher than 40℃ , the temperature rise limit of stator winding (by resistance method) ought to be no more than 80K, and the allowable temperature of bearing shall be no higher than 95℃ (by thermometer method). The surface temperature of each component should comply with stipulation T130℃ during starting and rated operation.

7.4 Start Mode

For the motor of 3kw or below, the winding has been connected as Y type; the motor of 4kw or above, the winding has been connected as Δ type. There are 6 terminals in connection box, and can be connected directly with 380V, 50 Hz three phase supply for full voltage starting. Connection method will be shown on connection box cover for custom-made double-voltage motor. The motor of other voltage and frequency shall subject to data on nameplate.

7.5 Transmission mode: motor can be connected by coupling, gear or V-belt pulley for driving machine, but flat-belt pulley is not allowed for connection.

7.6 Grounding: Each earth bolt shall be grounded safely before/during operation.

7.7 Fastening: All fastener of the motor, especially the components of terminal box, can not be disassembled or loosened optionally. The parts which must be disassembled (like terminal box cover) shall be cleaned after wiring, and then be assembled as original type. Ensure that all sealing gaskets have been put in the right position (not squeeze in or out) when reassembling so as to ensure motor's protection performance will not be degraded.

Chlorine foam rubber seal gasket shall be fitted between motor frame and end cover or the joining surface of bearing external cover with compression amount of 0.2~0.5 at mating surface, XH-50 rubber gasket shall be fitted tightly between terminal box body and motor frame. Replace a new one as original size when the old gasket is ageing or lose its effectiveness. The gasket cannot be optionally removed; otherwise it will cause the motor's explosion-proof function failure or affect its operation.

8 Maintenance and inspect

In maintenance and inspection the following issues shall be concerned:

8.1 Motor needs periodic inspection and maintenance. Inspect at least once every six months; overhaul once annually.

8.1.1 Inspection items:

- a. Check whether all grounding contact surface is clean.
- b. Check whether all electrical contact points are serviceable、 clean and in good contact.
- c. Check whether the lubrication of sealing part of bearing is clean and good.
- d. Check whether all mechanical connections (such as at external fan, fan cover, gasket) are reliable.
- e. Check and ensure that the distance between fan and fan cover is no less than 1% fan

diameter, but at least 1mm.

8.1.2 Overhaul includes all inspection item above as well as the following work:

- a. Clean dust and dirt out of the motor and coils.
- b. Replace grease (sealed bearing grease need not to be changed in the life cycle), ZL-2 lubricating grease for small medium size motor is recommended. re-grease duration and grease mass see table 5, Bearing type see table 6.
- c. Inspect motor winding insulation, colligation and electrical connection etc.
- d. Ageing sealing elements like rubber gasket、 grease sealing need to be replaced. The replace intervals see data on nameplate. Be careful when changing such sealing elements as they are vulnerable.

8.2 Replace bearing immediately when motor is found to make abnormal sound or grease to be spoiled (bearing specification see table 5).

8.2.1 The motor need to be overhauled at least once every 2500-h operation. Replace bearing lubrication grease immediately when it is found to be spoiled (There is no need to replace grease for Enclosed Bearing in its life span). Thoroughly clean the waste grease from internal/external bearing cover, chamber and discharging device, and clean the bearing completely.

8.2.2 It's recommend to fill with ZL-2 Lithium base grease 1/3~1/2 volume of the grease chamber. Applicable temperature range: -20-+120℃ , bearing life span is expected to be 50000h., Grease interval see table 4

8.3 After disassembling and inspection, clean all mating surface and apply some sealant before reassembling. Sealant should also be applied to the connecting bolts. If the in-lead cable need to be re-fitted, seal up the gap between stator lead-in cables and sealing collar with 303 resin after the lead wire is fixed onto connection bolt.

8.4 Motor winding connector、 lead-out wire、 cable joint are not allowed to bear any mechanical force; one of the following connection methods can be chosen:

- a.By screw and bolts that can prevent loosening;
- b.By extruding connection;
- c.Connect leads by mechanical method first and then by soldering;
- d.By hard soldering (such as silver soldering、 brazing and sliver brazing)
- e.By fusion welding.

8.5 Check and ensure that the distance between fan and fan cover is no less than 1% of fan diameter, but at least 1mm.

Table 4: Lubrication Grease Content and Lifespan

Frame	P	Grease content (g)	Re-lubrication interval (h)
160/180	2	20	4200
	4	20	7000
	6,8	20	9000
200	2	25	3100
	4	25	6500
	6,8	25	8500
225	2	25	3100
	4	30	6200
	6,8	30	6200
250	2	30	2600
	4	35	6000
	6,8	35	8000
280	2	35	2000
	4	40	5500
	6,8	40	7500
315	2	30	2500
	4,6,8,10	36	2500
355	2	36	2500
	4	47	2500
	6,8,10	47	2500

Note: Subject to practical situation.

Table 5: Bearing Type

Frame	Pole	DE	NDE
71	2,4,6	6202-2RZ	6202-2RZ
80	2,4,6,8	6204-2RZ	6204-2RZ
90	2,4,6,8	6205-2RZ	6205-2RZ
100	2,4,6,8	6206-2RZ	6206-2RZ
112	2,4,6,8	6206-2RZ	6206-2RZ
132	2,4,6,8	6208-2RZ	6208-2RZ
160	2,4,6,8	6309-2RZ	6309-2RZ
180	2,4,6,8	6311-2RZ	6311-2RZ
200	2,4,6,8	6312-2RZ	6312-2RZ
225	2,4,6,8	6313-2RZ	6312-2RZ
250	2	6313	6313
	4,6,8	6314	6313
280	2	6314	6314
	4,6,8	6317	6314
315	2	6317	6317
	4,6,8,10	NU319	6319
355	2	6319	6319
	4,6,8,10	NU322	6322

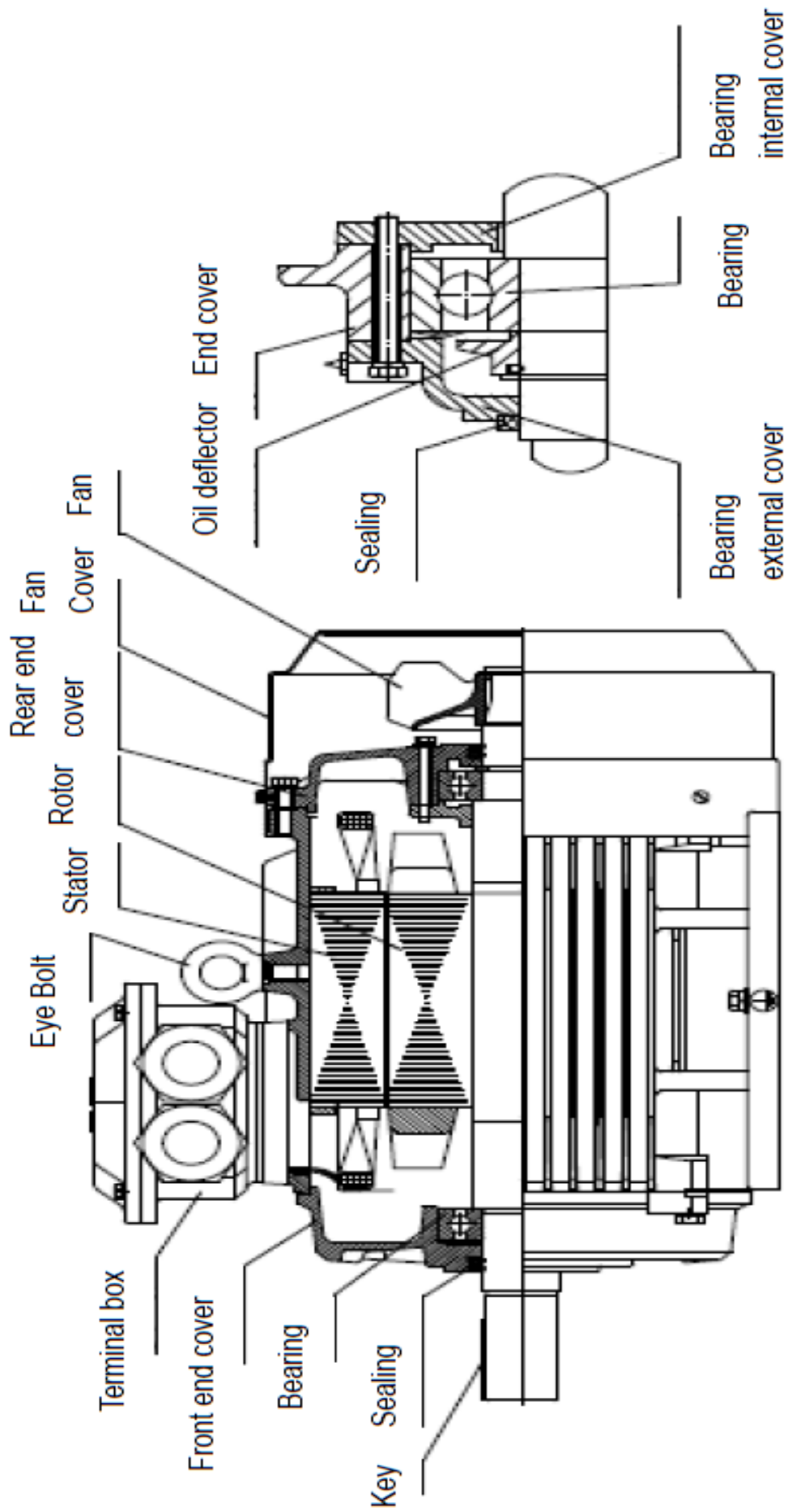

Figure 1 Motor subject structure (B3)

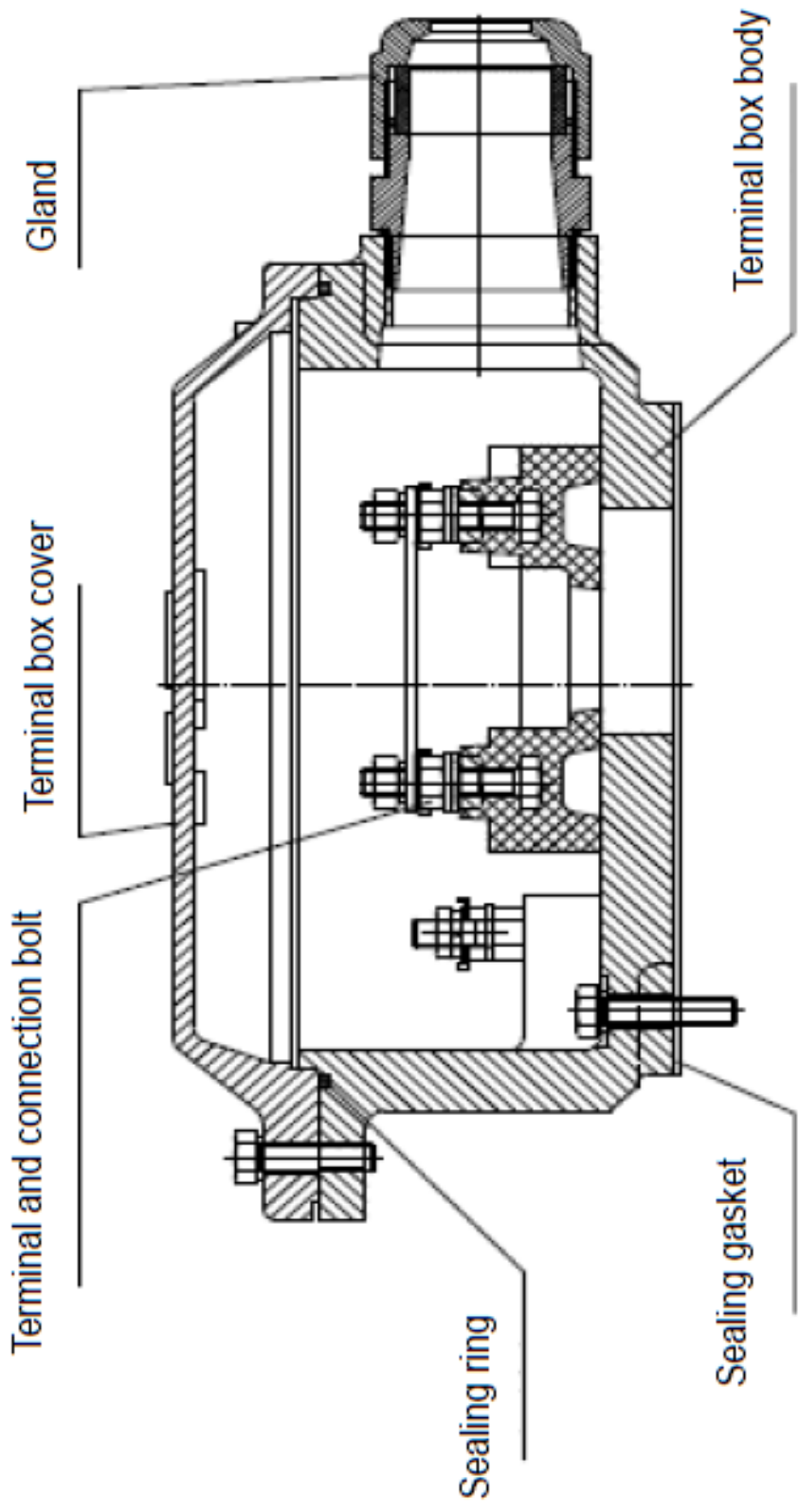

Figure 2 Terminal box structure

敬告用户：

请您按照本使用说明书的规定，正确地使用和储存电动机，我们将为您提供优质、快捷的服务。

在电动机使用过程中，您如有什么疑惑请与我们联系，我们将及时给予您满意的解答；您有什么良好的建议请向我们提出，以便我们改进，为您提供优质、快捷的服务。

安徽皖南电机股份有限公司对本使用说明书保留最终解释权。

请勿在未事先获得安徽皖南电机股份有限公司书面许可的情况下向第三方复制、公布或者使用本使用说明书内容。

Dear user,

Please use and store the motor right following the instruction of the manual. We will make our effort to provide you with high-quality and prompt service. Contact us if you had any questions in application, and we will offer you timely and effective resolution; let us know if you had any advices or suggestions, with which we can improve ourselves and make service better. Anhui Wannan Motor Co., Ltd. reserves the right of final interpretation of the user manual. No copy, disclosing or using of the content of this user manual to third parties prior to written permission from Anhui Wannan Motor Co., Ltd.

安徽皖南电机股份有限公司

Anhui Wannan Electric Machine Co.,Ltd

地址：安徽省泾县泾川镇南华路 86 号

Address: No.86 Nanhua Road Jingxian County Anhui Province P.R.C

销售处 Sales department: 400-111-0563 0563-5031908 5031988

客户服务中心 Customer service center: 0563-5031953

企业管理处 Enterprises management department: 0563-5031954

质量检验处 Quality inspection department: 0563-5031910 5031985

传真 Fax: (0563) 5029999 5023698

网址 Website: <http://www.wnmotor.com>

E-mail: wndjc@wnmotor.com

邮编 Postal code: 242500

本说明书内容如有变动，恕不另行通知。

Content in the manual may be changed without prior notice.